



**Xpipe Beveler (accessory for B-Line Machines)**  
Maximum bevel width 15 mm / 0.6 in. (10mm / 0.4 in.)  
Edge rounding function.

# *Xpipe Beveler*

## *Compatible with B10 Electra, B15 Electra and B15 Air*

Ergonomic, rotating handle increases work productivity

The bevel depth can be set continuously

Lightweight aluminum construction of the machine frame

Special one-way bearings for the roller shutters prevent any kickback

The Beveling Machine is not included with Xpipe Beveler

Art. Nr. 25500



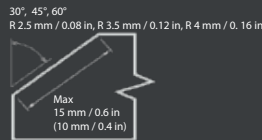

**Bevelling tool for easy and fast machining of pipes from Ø 85 mm (3.36").**  
**The maximum diameter of the pipe is not limited, and the tool can be used on flat materials.**  
**The unique mechanism of clamping, guiding rollers ensures precise and comfortable guiding around the circumference of the machined pipe or along the edge of the sheet metal.**  
**The robust frame of the body guarantees constant cut with a minimum of possible vibrations and uncompromising stability of the selected bevel angle.**

- Designed to work with B10 Electra, B15 Electra and B15 AIR bevelling machine
- Continuous bevel depth settings built-in scale
- Special one-way bearings preventing kickback of approaching material, safe and comfortable beveling
- The set removal value can be ensured, and a constant chamfer depth can be guaranteed even on a larger number of pipes
- Unique, flexible mounting of the running rollers, suitable for any unevenness and inaccuracies around the circumference of the pipe
- Lightweight aluminum construction of the machine frame guarantees comfortable handling of the product
- Ergonomic, rotating handle for productivity and safety
- Safety cover for flying chips, preventing possible injuries
- Packed in a plastic box

**Technical data:**

Bevel angle:	30°, 45° and 60°
Bevel width:	10 mm / 0.39" (with B10 Electra) 15 mm / 0.60" (with B15 Electra and B15 AIR)
Rounding app:	R 2,5 mm / R 0.10", R 3,5 mm / R 0.137", R4 mm / R 0.157"
Minimum ID (outside machining):	> Ø 85 mm / 3.36"
Wall thickness (outside machining):	2,5 - 15 mm / 0.10" - 0.60"
Minimum ID (inside machining):	> Ø 500 mm / 19.7" (smaller Ø on request)
Wall thickness (inside machining):	5 - 15 mm / 0.20" - 0.60"
Minimum clamping depth:	80 mm / 3.15"
Thickness working (flat bevelling):	3 - 20 mm / 0.11" - 0.78"
Feeding:	manual
Weight (without the machine):	8,4 kg/18.5 lb.

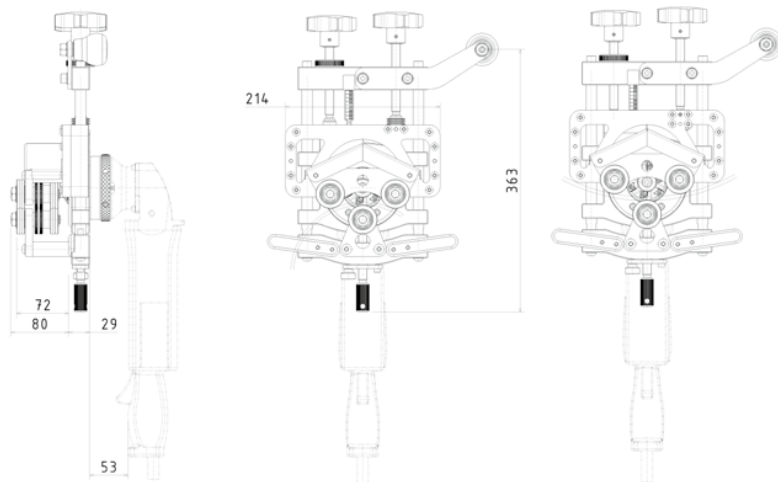

**Included in price:**

- Xpipe Beveler (without bevelling machine)
- Tools for an operator
- User manual

**Cost effective sets, see page 20-21**

**Machine name:**

The Xpipe Beveler (without bevelling machine)

**Art. Nr.**

25500





# Bevelling system B10 ELECTRA

Maximum bevel width 10 mm / 0.4 in. Edge rounding function.

# B10 Electra

High Performance  
Motor and Gearbox  



Art. Nr. 25300 (1 Phase - 220 V)  
Art. Nr. 25301 (1 Phase - 110 V)





**Designed for bevelling and deburring workpieces, internal and external radiuses and holes. Specially designed for producing bevels and welding preparation. Durable and stable machine design without compromises. Thanks to the special design of the cutting head you will you save ½ inserts at reductions of up to 8 mm / 0.31 in of the bevel width.**

- Scale for an accurate bevel size adjustment
- For bevelling and deburring steel, aluminum and other materials
- Replaceable head for changing bevel angle
- Handheld powerful equipment
- Electronic Speed Control
- Edge rounding function, preparation before surface treatment
- Packed in a cardboard box

**Technical data:**

Bevel angle: replaceable head 30°, 37,5°, 45°, 50°, 60°- other angles on demand  
 Bevel width: 0 to 10mm / 0 to 0.4 in < 400 MPa / 58 015 PSI  
 0 to 5mm / 0 to 0.2 in > 400 MPa / 58 015 PSI  
 Rounding app: R 2,5 mm, R 3,5 mm, R 4 mm / R 0,1 in, R 0,14 in, R 0,16 in  
 Engine: 1700 W  
 Speed: 2700 - 8 500 rpm  
 Overload protection: thermal  
 Feed: manual  
 Weight: 6 kg / 13.2 lb

**Included in price:**

Bevelling and deburring system B10 ELECTRA (without the head).  
 Tools for an operator.  
 User manual.

Machine name:	Art. Nr.
The B10 ELECTRA bevelling and deburring system (1 Phase - 220 V)	25300
The B10 ELECTRA bevelling and deburring system (1 Phase - 110 V)	25301

**Accessories:**

Milling heads	see page 14-15
B-Dock (Beveler B10 Electra is not included)	see page 16-17 (and price advantage sets page 20-21)
Xpipe Beveler (Beveler B10 Electra is not included)	see page 18-19 (and price advantage sets page 20-21)
Grinding adapter Edge Cleaner	see page 14
Special lubricating paste for the milling heads. Prevents seizing up, wear, cold-welding, solidifying of the threads 120g.	Art. Nr. 33005
Universal tube key (for milling head´s removing)	Art. Nr. 25300.27



Xpipe Beveler



B-Dock



Edge Cleaner



Cutting inserts



Milling heads



Rounding milling heads



Cutting inserts



Universal tube key

# B15 Electra



High Performance  
Motor and Gearbox

**REVOLVING ERGONOMIC HANDLE**



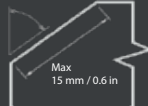

**Designed for beveling and deburring of parts, internal and external radiuses and holes.  
Specially designed for producing visual bevel and welding preparation.  
Powerful electric drive for extreme loads.**

- Scale for an accurate bevel size adjustment
- For beveling and deburring of steel, aluminum and other materials
- Replaceable head for changing bevel angle
- Handheld powerful equipment
- Swivelling ergonomic handle
- Edge rounding function, preparation before surface treatment
- Packed in a cardboard box

**Technical data:**

Bevel angle: Replaceable head 30°, 37,5°, 45°, 50°, 60°- other angles on demand  
 Bevel width: 0 to 15 mm / 0 to 0.6 in < 400 MPa / 58 015 PSI  
 0 to 8 mm / 0 to 0.3 in > 400 MPa / 58 015 PSI  
 Rounding app: R 2,5 mm, R 3,5 mm, R 4 mm / R 0,1 in, R 0,14 in, R 0,16 in  
 Engine: 2500 W / 2000W  
 Speed: 6600 rpm  
 Weight: 9.5 kg / 20.9 lb

**Included in price:**

Beveling and deburring system B15 ELECTRA (without the head).  
 Tools for an operator.  
 User manual.

**Machine name:**

**Art. Nr.**

Beveling and deburring system B15 ELECTRA (1 Phase - 220 V)	25250
Beveling and deburring system B15 ELECTRA (1 Phase - 110 V)	25251

**Accessories:**

Milling heads	see page 14-15
B-Dock (Beveler B15 Electra is not included)	see page 16-17 (and price advantage sets page 20-21)
Xpipe Beveler (Beveler B15 Electra is not included)	see page 18-19 (and price advantage sets page 20-21)
Grinding adapter Edge Cleaner	see page 14
Special lubricating paste for the milling heads. Prevents seizing up, wear, cold-welding, solidifying of the threads 120g.	Art. Nr. 33005
Universal tube key (for milling head's removing)	Art. Nr. 25300.27



Xpipe Beveler



B-Dock



Edge Cleaner



Cutting inserts



Milling heads



Rounding milling heads



Cutting inserts



Universal tube key





# Bevelling system B15 AIR (B15 AIR-S)

Maximum bevel width 15 mm / 0.6 in. Edge rounding function.

# B15 Air



Low RPM version  
B15 Air-S  
for Stainless

Powerful 2984 W pneumatic motor

Heavy-duty design

Machining depth  
adjustment



Art. Nr. 27220 (B15 AIR)  
Art. Nr. 27220S (B15 AIR-S)



## HEAVY-DUTY





**Designed for bevelling and deburring of straight and shaped parts, internal and external radiuses and holes. Specially designed for producing visual bevels and welding preparation. Powerful pneumatic drive for extreme loads.**

- Scale for an accurate bevel size adjustment
- For bevelling and deburring of steel, aluminum and other materials
- Replaceable head for changing bevel angle
- Powerful handheld equipment
- Also suitable for explosion-risk operations
- Edge rounding function, preparation before surface treatment
- Low RPM model for processing of stainless steel
- Packed in a cardboard box

**Technical data:**

Bevel angle:	Replaceable head 30°, 37,5°, 45°, 50°, 60°- other angles on demand
Bevel width:	0 to 15 mm / 0 to 0.6 in < 400 MPa / 58 015 PSI 0 to 8 mm / 0 to 0.31 in > 400 MPa / 58 015 PSI
Engine:	Pneumatic
Engine Power:	2984 W
Speed:	6000 rpm (B15 AIR-S 4200 rpm)
Air consumption:	750 l/min
Operating pressure:	6 bar / 87.02 PSI
Weight:	7,5 kg / 16.5 lb

**Included in price:**

B15 AIR bevelling and deburring system (without the head).  
Tools for an operator.  
User manual.

Machine name:	Art. Nr.
Bevelling and deburring system B15 AIR	27220
Bevelling and deburring system B15 AIR-S	27220S

Accessories:	
Milling heads	see page 14-15
Xpipe Beveler (Beveler B15 Air is not included)	see page 18-19 (and price advantage sets page 20-21)
Grinding adapter Edge Cleaner	see page 14
Pneumatic set with quick couplings (contains: FRL - filtration, regulator and lubrication unit, quick couplings, hoses 10 m)	Art. Nr. 27221
Special lubricating paste for the milling heads. Prevents seizing up, wear, cold-welding, solidifying of the threads 120g.	Art. Nr. 33005
Universal tube key (for milling head´s removing)	Art. Nr. 25300.27

























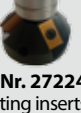

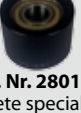
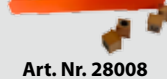
### The Premium milling heads for processing tougher materials.

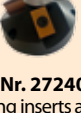
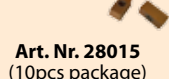
- For B10 Electra, B15 Electra and B15 AIR hand held bevelers
- Developed especially for stainless steel and other tougher materials
- More effective increased safety
- Smoother final surface and higher lifetime for the cutting inserts
- Longer cutting inserts (15 mm/0.6") are standard and two-sided
- Shorter cutting inserts (8 mm/0.3") are four-sided » double lifetime

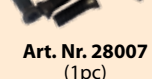
Required bevel angle	The starter kit Premium milling head max 15 mm/0.6" two sided cutting inserts	The spare two sided cutting inserts 15 mm/0.6"	The additional special roller for shorter cutting inserts 8 mm/0.3" (the milling head stays original)	The shorter four sided cutting inserts 8 mm/0.3"	The fastening screws for the cutting inserts (works with both cutting inserts versions)
30°	 <b>Art. Nr. 27223X</b> (the cutting inserts and the lead roller Ø 30 mm / 1.19" are included)	 <b>Art. Nr. 28015</b> (10pcs package)	 <b>Art. Nr. 28004</b> (complete special lead roller Ø 33,5 mm / 1.32" for shorter cutting inserts)	 <b>Art. Nr. 28008</b> (10pcs package)	 <b>Art. Nr. 28007</b> (1pc)
37.5°	 <b>Art. Nr. 27227X</b> (the cutting inserts and the lead roller Ø 26 mm / 1.02" are included)	 <b>Art. Nr. 28015</b> (10pcs package)	 <b>Art. Nr. 28013</b> (complete special lead roller Ø 30,5 mm / 1.2" for shorter cutting inserts)	 <b>Art. Nr. 28008</b> (10pcs package)	 <b>Art. Nr. 28007</b> (1pc)
45°	 <b>Art. Nr. 27222X</b> (the cutting inserts and the lead roller Ø 26 mm / 1.02" are included)	 <b>Art. Nr. 28015</b> (10pcs package)	 <b>Art. Nr. 28005</b> (complete special lead roller Ø 31 mm / 1.23" for shorter cutting inserts)	 <b>Art. Nr. 28008</b> (10pcs package)	 <b>Art. Nr. 28007</b> (1pc)
50°	 <b>Art. Nr. 27224X</b> (the cutting inserts and the lead roller Ø 26 mm / 1.02" are included)	 <b>Art. Nr. 28015</b> (10pcs package)	 <b>Art. Nr. 28014</b> (complete special lead roller Ø 31,5 mm / 1.24" for shorter cutting inserts)	 <b>Art. Nr. 28008</b> (10pcs package)	 <b>Art. Nr. 28007</b> (1pc)
60°	 <b>Art. Nr. 27240X</b> (the cutting inserts and the lead roller Ø 19 mm / 0.75" are included)	 <b>Art. Nr. 28015</b> (10pcs package)	 <b>Art. Nr. 28006</b> (complete special lead roller Ø 25,5 mm / 1.01" for shorter cutting inserts)	 <b>Art. Nr. 28008</b> (10pcs package)	 <b>Art. Nr. 28007</b> (1pc)
<b>Other angles on demand</b>					

### Edge Cleaner - grinding adapter









Edge Cleaner - grinding adapter (including 10pcs grinding rings grain 40, 1pc guiding roller)	Grinding rings, grain 40 (pack 50pcs)	Spare polyurethane guiding roller
 <b>Art. Nr. 25310</b>	 <b>Art. Nr. 25312</b>	 <b>Art. Nr. 25311</b>

# Milling Heads and other accessories for B10 Electra, B15 Electra and B15 Air



## The Rounding milling heads

- For B10 Electra, B15 Electra and B15 AIR hand held bevelers
- Smoother final surface and higher lifetime for the cutting inserts
- For edge rounding application

Required radius	Complete radius milling head, including of the guiding roll and fastening screw	Radius 4 - sided cutting inserts	The fastening screws for the cutting inserts
R 2.5 mm / 0.08 in	 <b>Art. Nr. 27234X</b> (the cutting inserts and the lead roller Ø 37 mm / 1.46" are included)	 <b>Art. Nr. 26109</b> (10pcs package)	 <b>Art. Nr. 28007</b> (1pc)
R 3.5 mm / 0.12 in	 <b>Art. Nr. 27233X</b> (the cutting inserts and the lead roller Ø 37 mm / 1.46" are included)	 <b>Art. Nr. 26110</b> (10pcs package)	 <b>Art. Nr. 28007</b> (1pc)
R 4 mm / 0.16 in	Compatible with the milling head R 3.5 mm / 0.12"  <b>Art. Nr. 27233X</b>	 <b>Part no. 26111</b> (10pcs package)	 <b>Part no. 28007</b> (1pc)

## The older ECO milling heads. Available while supplied last.

	Art. Nr.
30° cutting head (including inserts, screws, bolts and roller). Guide roller diameter Ø 34 mm / 1.34 in	27223
50° cutting head (including inserts, screws, bolts and roller). Guide roller diameter Ø 28 mm / 1.10 in	27224
Coated cutting inserts - four-sided (pack of 10 pcs)	27231
Screw for the inserts	27241

## Lubricating paste

	Art. Nr.
Special lubricating paste for the milling heads. Prevents seizing up, wear, cold-welding, solidifying of the threads 120g.	33005
Universal tube key (for milling head's removing)	25300_27
Magnetic sweeper Mag Brush	18654



Art. Nr. 27223



Art. Nr. 27231



Thousands of satisfied customers throughout the world



# ***B-Line sets!***

## ***Compactible accessories for B10 Electra, B15 Electra and B15 Air***





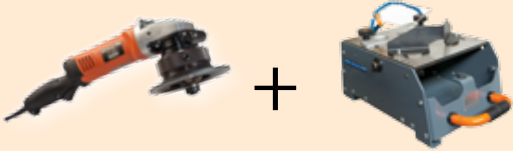

Cost effective accessories sets for B10 Electra, B15 Electra and B15 Air.





These accessories will transform your B-line into a versatile tool, which can handle most of your future projects.

You can bevel flat steel, or tubes, small workpieces or you can do rounding of the plate edges. All in one solution!

<i><b>B10 Electra sets</b></i>	<b>Set 230V</b>	<b>Set 120V</b>
 <p>B10 Electra                      B-Dock</p>	Art. Nr. 25302	Art. Nr. 25303
 <p>B10 Electra                      Xpipe Beveler</p>	Art. Nr. 25304	Art. Nr. 25306
 <p>B10 Electra                      B-Dock                      Xpipe Beveler</p>	Art. Nr. 25305	Art. Nr. 25307



<b>B15 Electra sets</b>		<b>Set 230V</b>	<b>Set 120V</b>
 +  B15 Electra                      B-Dock		Art. Nr. 25252	Art. Nr. 25253
 +  B15 Electra                      Xpipe Beveler		Art. Nr. 25254	Art. Nr. 25256
 +  +  B15 Electra                      B-Dock                      Xpipe Beveler		Art. Nr. 25255	Art. Nr. 25257

<b>B15 Air sets</b>		<b>Pneumatic powered</b>
 +  B15 Air                      Xpipe Beveler		Art. Nr. 27225
 +  B15 Air - S                      Xpipe Beveler		Art. Nr. 27225S

# B-Dock

## Compatible with B10 Electra and B15 Electra

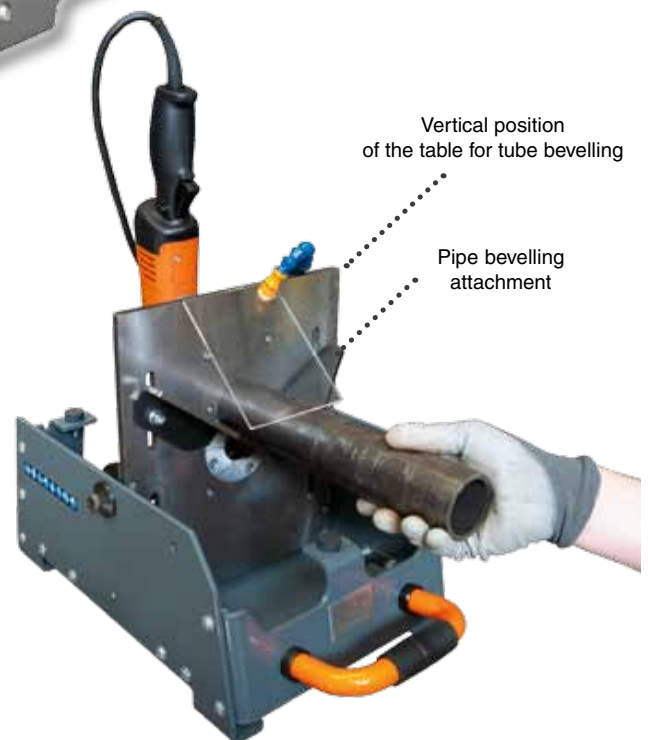
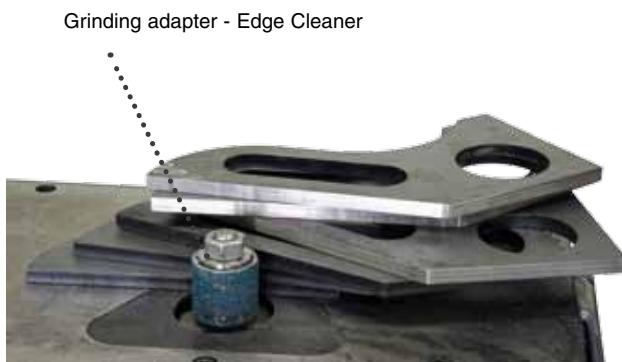



Dock station B-Dock enables the B-Line Machine (B10, B15 Electra) to be used stationary. It is designed for beveling small workpieces which would be hard or impossible to clamp and bevel the standard way. The system retains all advantages of the hand-held B-Line Machines (B10, B15 Electra). The B-dock system makes it possible to bevel irregular shapes, straight workpieces and holes. Radiused edges are also possible with the radius milling head. Specialty guide attachments and an easy, vertical worktable adjustment allow for beveling of pipe and tube.

By purchasing the set B-Dock + B10 or B15 Electra you are getting a universal beveling system.

- Tilting table for easy attachment of B10, B15 Electra
- Vertical position of the table for convenient pipe beveling
- Straight edge and pipe guide attachments included in the price
- Adjustable protection shield increases work safety
- Robust design for precision beveling and durability of the B-dock
- The Hardox work surface is wear resistant
- Light weight system is easy to transport
- Can be used with B15 Electra or B10 Electra machines
- Packed in a cardboard box

**Technical data:**

Bevel angle: see previous page (technical date for B10, B15 Electra)  
 Bevel width: 0 to 5mm / 0 to 0.2 in  
 Rounding app: see previous page (technical date for B10, B15 Electra)  
 Motor: see previous page (technical date for B10, B15 Electra)  
 RPM: see previous page (technical date for B10, B15 Electra)  
 Feed: manual  
 Weight: 28kg / 62 lb  
 Dimensions: 443 x 368 x 220mm / 17,5 x 14,5 x 8,7 in

**Included in price:**

Dock station B-dock (without bevelling machine)  
 Tools for an operator  
 Manual

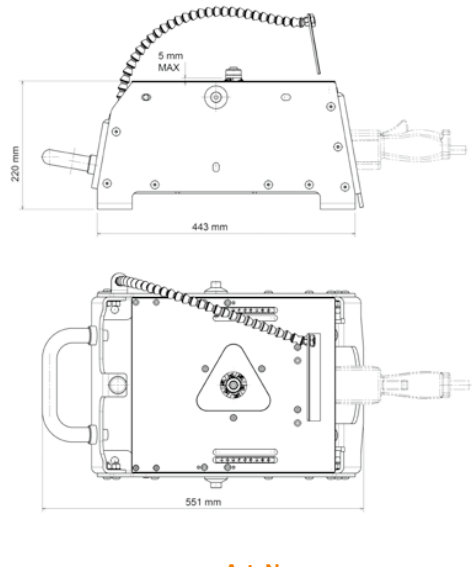

**Machine name:**

The Beveling System B-Dock (without bevelling machine)	<b>Art. Nr.</b> 25350
--	--------------------------

**Accessories:**

Head cover for radius heads	<b>Art. Nr.</b> 25350.6RT
Protection felt plug	25315

*Cost effective sets, see page 20-21*



Pipe bevelling attachment



Straight edge bevelling guide



Protection felt plug

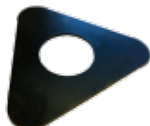

Head cover

